

LED Vanity Lamp

EW3506
INSTALLATION SHEET

START FROM HERE

- Make sure **POWER** is **COMPLETELY OFF** at the fuse box
- Have your fixture installed by a qualified licensed electrician
- Prepare everything in a clear area
- Wear gloves at all time during this installation
- Read instructions carefully before you start assembly
- Keep this installation sheet for future reference

Please Note:

- This Kuzco LED fixture comes with pre-wired LED module(s)
- Unless instructed, Do Not touch any part of the LED module(s) as any unnecessary contact with the module could cause permanent damage
- Use ELV (Electronic Low Voltage) type of dimmer for dimming application

Technical Support: 1-855-855-8926

- 1.** Remove the fixture from its original packaging. First remove the set screws (**2d**) from the side of the lamp cover (**2e**) using the allen key provided. Now remove the mounting plate (**1c**) from the backplate (**2b**) by removing the round nuts (**2c**). Attach the mounting plate (**1c**) to the electrical junction box (**1a**), using the screws (**1d**) provided in the hardware package.
- 2.** Attach the backplate (**2b**) to the mounting plate (**1c**). First attach all wiring with the provided marrets (**2a**) (white to white "N", black to black "L", ground to ground "G"). Push the fixture backplate (**2b**) onto the mounting plate (**1c**), then thread the round nuts (**2c**) into the mounting plate studs (**1b**). Next, place the lamp cover (**2e**) over the backplate (**2b**) and secure with set screws (**2d**).
- 3.** To prevent moisture from entering the outlet box and causing a short, seal around the top and side perimeter between the fixture and the wall surface with weather resistant caulking (**see illustration 1**). The space at bottom should be left un-caulked to prevent moisture build-up. Apply a small amount of weather resistant caulking around the side perimeter between the cap nut and mounting plate.
- 4.** You have now completed the installation of your fixture, please enjoy.

Illustration 1

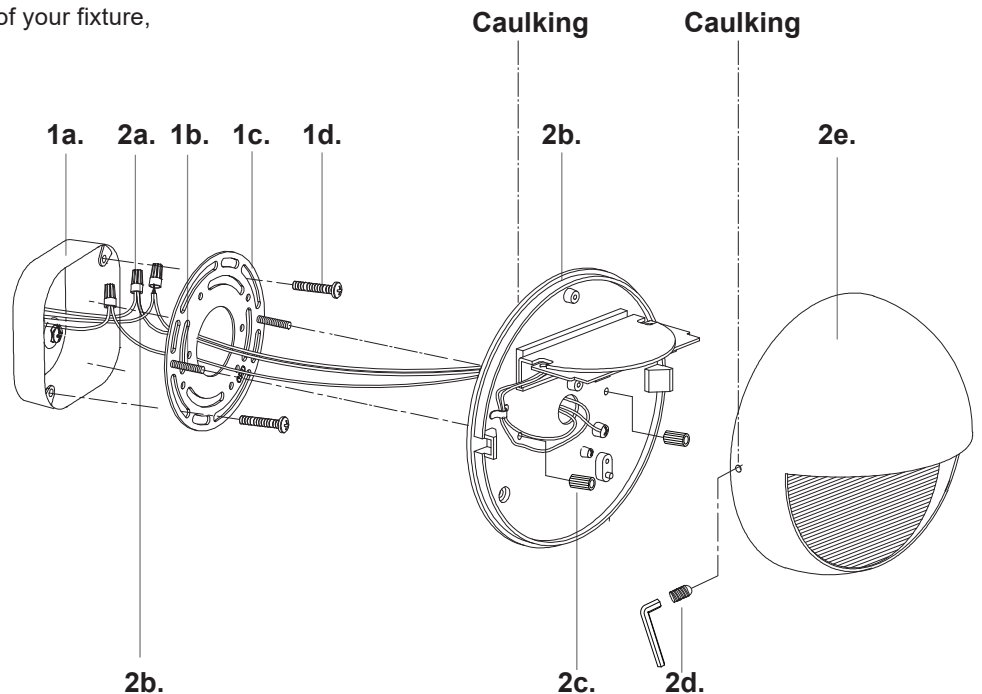
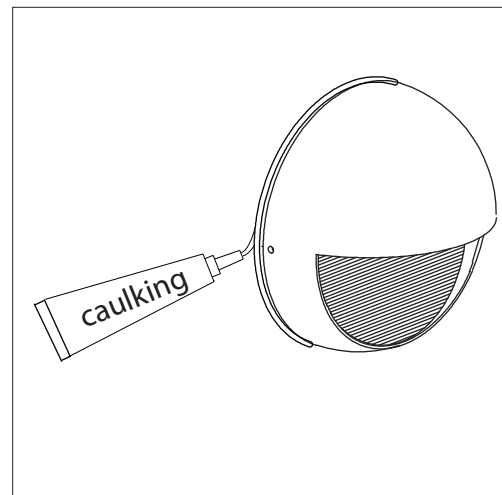

KUZCO

19054 28th Avenue Surrey, BC Canada V3Z 6M3
T: 604 538 7162 TF: 1-855 85 KUZCO F: 604 538 7196
W: kuzcolighting.com
20190814